

Installation, Operation, and Maintenance Instructions 2-Way, Flush Tank, and Diverter Port Ball Valves SP, FT, & DP Series 0, 1/2" thru 6"



WARNING:

For your safety and protection it is important that the following precautions be taken prior to working on the valve.

1. Depressurize and drain the line.
2. Cycle the valve to relieve any pressure trapped in the valve.
3. Disconnect any air and electrical connections to the valve assembly.
4. Know what the media is in the line and wear appropriate protective clothing and equipment. Obtain appropriate MSDS sheets.
5. To ensure safe product selection and operation, it is the responsibility of the process system designer and end user to determine the appropriate compatible materials of construction and adequate product ratings for the process system. Process system designer, installer, and end user are responsible for proper installation, operation, and maintenance.
6. Fasteners are designed to prevent loosening under normal operating conditions. Prior to commissioning at final point of operation, all valves should be inspected to ensure fasteners are tightened to manufacturer's recommendations and no damage has occurred during transit or handling.
7. When disposing of Teflon parts, do not incinerate or subject to open flames.

1. General

This Installation, Operation, and Maintenance manual is for the safe use of PBM 3-piece, Adjust-O-Seal®, Bi-Directional, SP, FT, and DP Series 0 ball valves. Please read instructions carefully and save for future reference.

2. Installation

Fasteners are designed to prevent loosening under normal operating conditions. Prior to commissioning at final point of operation, all valves should be inspected to ensure fasteners are tightened to manufacturer's Recommendations and no damage has occurred during transit or handling. SP, FT, and DP valves may be installed in either flow direction with the valve in the "open" position. SP and DP valves do not need to be disassembled before installation except for socket weld, butt weld, sil-braze, or solder joint end connections. For FT valves, disassemble the valve and attach the tank pad to the vessel. Reassemble valve to tank pad. See IOM-WELD for welding of end connections or tank pads.

3. Operation

For manual valves, operation consists of turning the handle 1/4 turn to close or open the valve. When handle is parallel with the pipeline, the valve is in the open position. These valves may also be automated with actuators and other valve automation equipment. Mechanical handle stops must be removed if manual valves are converted to automated valves. For automated valves, operation is controlled by the actuator placed on top of the valve. Valve stops are an integral part of the actuators. Good operating procedure requires periodic inspection of the valves and replacement of parts as required. Always use PBM factory authorized replacement parts.

Follow instructions to ensure optimum performance:

Adjusting for Normal Wear

Note: Valve to be in fully opened or fully closed position prior to adjustments.

1. PBM Ball Valves are designed with the Adjust-O-Seal® feature. If the valve shows signs of leakage due to normal seat wear, tighten the end fitting fasteners evenly in 1/8 turns, in the staggered sequence as shown at bottom of Page 3, until the leakage stops and the valve operates smoothly:
 - a) Initially, there should be a space between end fittings and the body. This space is the key to the Adjust-O-Seal® feature and allows in-line adjustment of the seats and gasket.
 - b) End fitting fasteners should be tightened only until valve stem breakaway torque is reached (Torque Table - Page 3).
2. If valve shows signs of leakage in stem area due to normal stem packing wear, tighten gland nut until leakage stops and valve operates smoothly.
3. After adjustments have been made to seats, or if packing leakage cannot be stopped, a repair kit will be required.

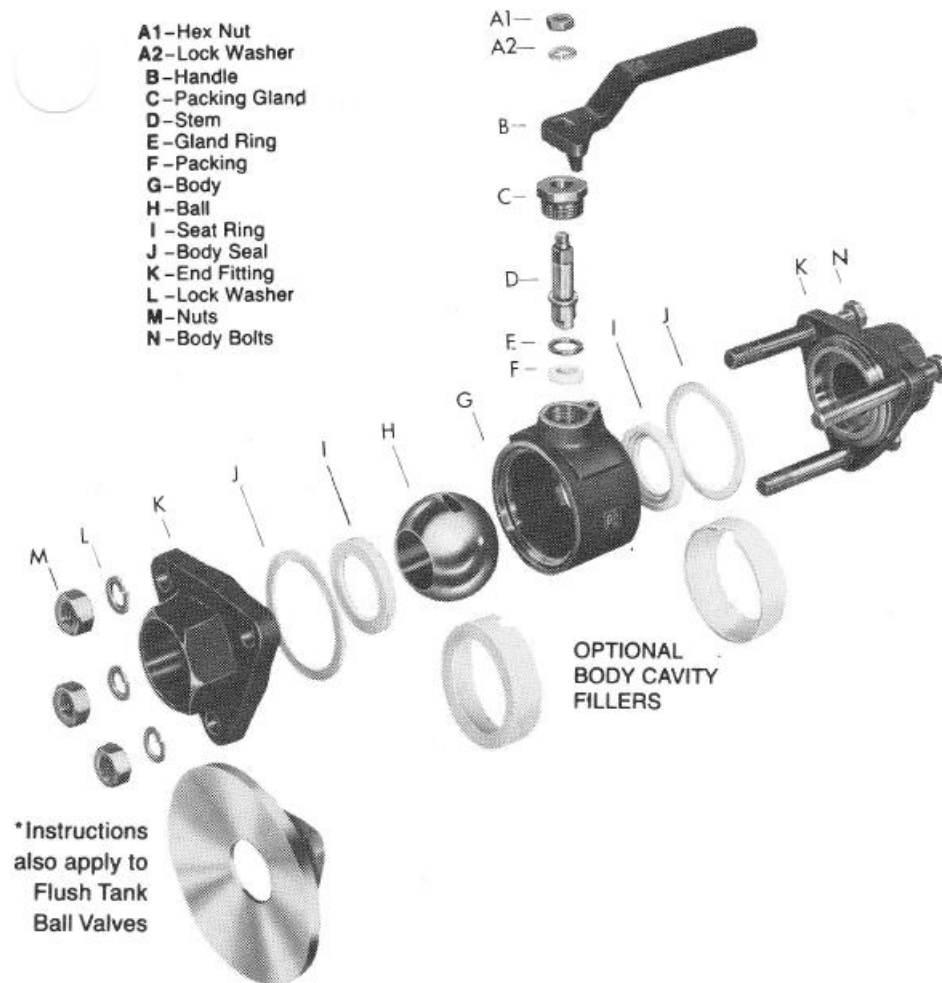

Disassembly of valve:

1. Isolate and depressurize the associated piping system. Cycle the valve to ensure there is no trapped pressure or fluid in the valve cavity. The valve should be left fully closed position for SP and FT valves.
2. **For Automated Valves Only:** Remove all air and electrical power from the actuator, solenoid valve, and switchbox, if any. Then remove the automation assembly from the valve. Retain coupling and mounting bracket.
3. **For Manual Valves Only:** Loosen and remove the hex nut and lock washer from the stem and then remove the handle.
4. Loosen and remove the hex nuts and lock washers from the fasteners. Remove the fasteners. Pull the end fitting(s) free from the body. Remove the body subassembly.
5. Remove the seat, gaskets, and cavity fillers, if any.
6. Remove gland, stem, gland ring, and stem packing from valve body.
7. Ball is now free so remove it, taking care not to nick or scratch the ball.

Reassembly of valve:

1. Before reassembling the valve, examine the parts and repair or replace damaged or worn parts. Clean metal parts, as necessary, using a solvent compatible with the process fluid and a non-abrasive cloth. PBM recommends using new seats, body gaskets, and seals at each assembly.
2. Replace ball in body, making certain not to scratch the exterior surface.
3. Place new stem packing, gland ring (bevel side down), stem, and gland (Lubricate the stem and gland threads with an anti-galling lubricant.) into valve body in sequential order. Engage stem into ball (a rubber hammer may be used due to light press fit) and tighten gland to hand tight position.
4. Place seats, body gaskets, and cavity fillers, if any, into proper position in end fittings. Place end fittings into proper locations on valve body sections and tighten body bolts hand tight, making certain ball port is centrally located with end fitting inside diameters. Lubricate external threads of body bolting with anti-galling lubricant.

- Wrench-tighten the bolting or hex nuts according to the procedure shown below, while maintaining an even gap between the body and end fittings, and until the stem torque, as shown in the torque table on below is reached. The torque is the measured stem torque as the valve leaves the closed position. Cycle the valve to verify freedom of operation and torque. If practical, check the valve seats and seals for leaks. Check port alignment as well.
- For Automated Valves Only:** Reinstall the automation assembly with the bracket and coupling. Then reconnect air and electrical power.

Tightening Procedure for End Fittings:

- Hand tighten fasteners.
- Wrench tighten each fastener in increments per the staggered sequence illustrated at right until the spring washers begin to compress.
- Continue tightening bolts or hex nuts 1/8 turn until the recommended torque value is achieved when measuring at the valve stem.

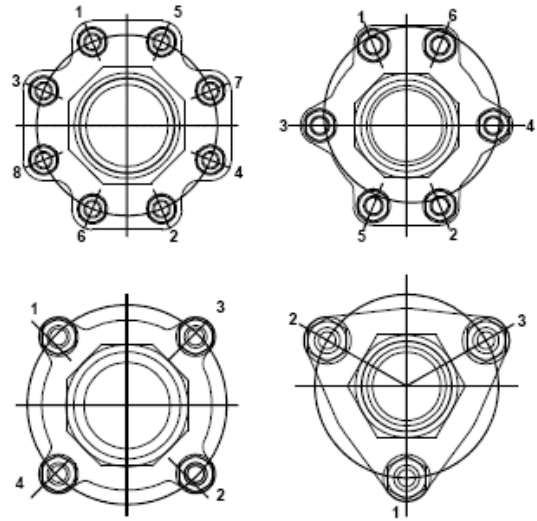

Valve Size	Size Code	Valve Stem Nominal Breakaway Torque – RTFE™ Seats	
		in – lbs.	N-m
1/2"	C0	48	5.4
3/4"	D0	60	6.8
1"	E0	72	8.1
1-1/4"	F0	132	14.9
1-1/2"	G0	168	19.0
2"	H0	192	21.7
2-1/2"	J0	300	33.9
3"	K0	420	47.5
4"	L0	540	61.0
6"	M0	1,920	216.9

Notes for Table at left:

- Stem torques are shown in nominal values and represent ideal conditions. (100 psig / 6.9 bar or less, ambient temperature, with fluid free of suspended solids and comparable in viscosity to water).
- For UHMWPE seats, multiply by 1.25. For S-TEF® or Kynar seats, multiply by 1.56. Consult factory for PEEK seat torques.
- Torque values measured at the stem, NOT at the fasteners.

Replacement Kits and Parts					
Valve Size	SP, FT Repair Kit (RTFE)	SP, FT Cavity Filler Kit (VTFE)	SP, FT Ball (316L S/S)	Stem (316L S/S)	Gland
1/2"	SPRTC0 -- 1	SPVTC1 -- D -- 3	SPHLC002	SPHLC005	SPK-C006
3/4"	SPRTD0 -- 1	SPVTD1 -- D -- 3	SPHLD002	SPHLC005	SPK-C006
1"	SPRTE0 -- 1	SPVTE1 -- D -- 3	SPHLE002	SPHLE005	SPK-E006
1-1/4"	SPRTF0 -- 1	SPVTF1 -- D -- 3	SPHLF002	SPHLF005	SPK-F006
1-1/2"	SPRTG0 -- 1	SPVTG1 -- D -- 3	SPHLG002	SPHLH005	SPK-H006
2"	SPRTH0 -- 1	SPVTH1 -- D -- 3	SPHLH002	SPHLH005	SPK-H006
2-1/2"	SPRTJ0 -- 1	SPVTJ1 -- D -- 3	SPHLJ002	SPHLJ005	SPK-J006
3"	SPRTK0 -- 1	SPVTK1 -- D -- 3	SPHLK002	SPHLK005	SPK-K006
4"	SPRTL0 -- 1	SPVTL1 -- D -- 3	SPHLL002	SPHLK005	SPK-K006
6"	SPRTM0 -- 1	SPVTM1 -- D -- 3	SPHLM002	SPHLM005	SPK-M006

Notes for Table above:

1. For Sanitary repair kits, change SP repair kits to use VTFE – example SPVTC0--1.
2. Standard repair kits include 2 RTFE seats, 2 RTFE body gaskets, and multiple RTFE stem packings.
3. Cavity filler kits include 2 VTFE fillers.
4. Standard repair kits and replacement parts are RTFE or VTFE.
5. Replacement parts are one each per part number.
6. For materials other than RTFE, substitute the correct material ID and code.
7. For DP Cavity Filler Kits, please consult factory.

Material Definitions:

HT	S-TEF®	Stainless steel reinforced polytetrafluoroethylene
RT	RTFE	Glass reinforced polytetrafluoroethylene
VT	VTFE	Virgin Polytetrafluoroethylene
PK	PEEK™	Polyetheretherketone
UT	UHMWPE	Ultra High Molecular Weight Polyethylene
KY	KYNAR	Polyvinylidene Fluoride



1070 Sandy Hill Road, Irwin, PA 15642

Phone: (724) 863-0550 or (800) 967-4PBM Fax: (724) 864-9255
 E-mail: info.pbmvalve@imi-critical.com Web: www.pbmvalve.com
 © Copyright 2021 PBM, Inc. IOM-S0 R0 10/21 Printed in USA

